

VR-500 Airworthy Data Link System

The VR-500 is a Multiple Participant Airborne S-Band TDMA data link with up to 400 time slots per second. Transmission rate is up to 714Kb/sec. A typical application includes 20 airborne participants sharing 200 time slots per second. Each participant may broadcast 300 bytes of data messages 10 times per second (10Hz). While one participant transmits, the rest of the participants listen.

With an airborne omni directional antenna, the DataLink has a useful range of 60-70NM. A Ground Station with high gain antennas provides ranges exceeding 120NM.

VR-500 Salient Features

- ◆ Frequency Band: 2.2-2.35GHz
- ◆ Transmitter power: 50Watt
- ◆ Data modulation: PCM NRZ-L
- ◆ Transmission: up to 714Kbit/sec
- ◆ Typical bits per slots: 2500 bits
- ◆ Slots per second: 100-400 time slots.
- ◆ Receiver sensitivity: -94dBm at E/N = 14dB.
- ◆ Control: MIL-STD-1553, RS-422, or Ethernet

Datalink LRUs

VR-500 Datalink includes 3 airworthy LRUs:

- ◆ AMC-1000 Processor Unit
- ◆ S-Band Transceiver
- ◆ DataLink Power Supply Unit (PSU)

Airborne FM Transceiver Description

- ◆ Power 50Watt (47dbm).
- ◆ Antenna impedance: 50 ohm nominal
- ◆ Modulation: FM Transceiver
- ◆ Number of frequencies: 8 programmable.
- ◆ IF bandwidth: -3 dB 0.7 MHz min., -60 dB 3.0 MHz max.
- ◆ Image and spurious rejection: 60 dB min. Dynamic range: 50 dB min.
- ◆ Audio output impedance 75 ohm.
- ◆ PCM output level 2V p-p $\pm 10\%$ for 175 kHz peak deviation
- ◆ PCM output response: 10 Hz to 350 kHz ± 1.5 dB at 175 kHz peak deviation
- ◆ Sensitivity: -94 dBm for $(S + N)/N = 14$ db at peak deviation of 175KHz.
- ◆ Signal strength indication: 1.4V into ± 10 KW load (Linear monotonic voltage for RF signal range of -90.4 to -40dBm).

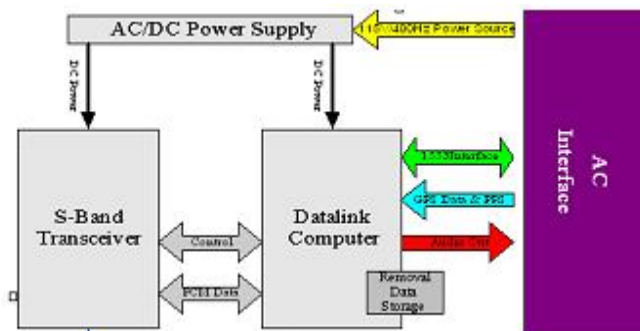

- ◆ Dimensions: 330x100x 70 [mm],
- ◆ Weight: 2.5Kg

The transceiver frequencies are 2200-2300MHz, or 2250-2350MHz. The transceiver has very fast transition from Transmit to Receive and vice versa. This characteristic is essential for efficient TDMA transmissions. The receiver has -94dBm sensitivity at E/N = 14dB.

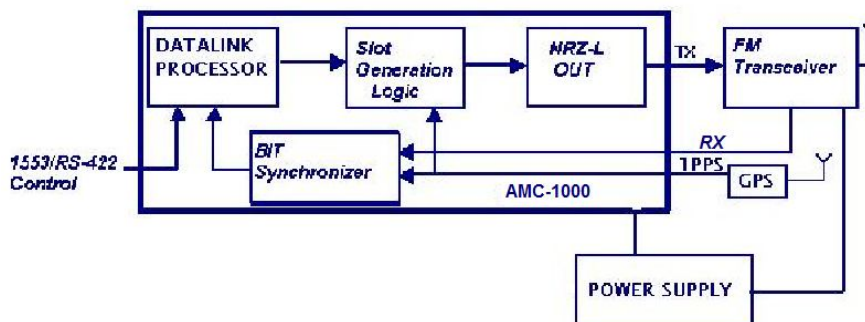

VR-500 Airworthy Data Link System

VR Processor

The VR Processor is based on Airworthy AMC-1000 PC with XP Embedded and a data link modem. The PCM data pulses (NRZ-L) are transmitted in the selected time-slots as set by the system software. Bit stream from the FM receiver is processed by a digital BIT Synchronizer and handed over to the application program in the Processor. The standard interface of the VR Processor with the Plane bus is via MIL-STD-1553 or LAN. Additional I/Os and interfaces such as RS-422, discrete lines, and Audio for Voice announcements, are available. In addition, the VR Processor supports the following:

- ◆ Dual Core ATOM D510 (2 Cores 4 Threads).
- ◆ 8-64GB SATA Flash disk
- ◆ DRAM - 1GB
- ◆ 100BaseT Ethernet
- ◆ 4 x RS-422
- ◆ Audio out for voice messages to Pilot.
- ◆ MIL-STD-1553 BM, RT, BC
- ◆ 4 x USB 2.0
- ◆ 4 x 100 BaseT LAN.
- ◆ 8 x discrete signals (OUT).
- ◆ 8 x discrete signals (IN).



Power Supply

The Datalink LRUs use 120W input power (average) from 115VAC 400Hz/1 phase.

Dimensions: 255x100x100 [mm].
Weight: 2.5Kg



Antennas

Two Omni directional S-Band Airborne antennas are used for spherical coverage. The front Antenna installed on the nose transmits approximately 35W. It provides coverage to the front and sides of the plane; A lower AFT antenna connected via a power divider, transmits approximately 7W. It's purpose to provide coverage to rear side of the plane.

Environmental Conditions

Temperature:

The DataLink LRUs will not be damaged or affected by the effects of ambient air temperature as follows:

Operating: -40° to +71°C

Non-operating: (Storage) from -54° to 85°C.

Relative Humidity

Operating: 95% relative humidity (RH), no condensation.
Non-operating: 95% RH.

Vibration

According to MIL-STD-810E for airborne environment.

Shock

According to MIL-STD-810E, 40g for duration of 11msec.

Fungus

The VR-500 LRUs are non-nutrient to fungus growth according to the requirements in MIL-STD-810E.

Sand and Dust

The VR-500 LRUs shall operate as specified herein while and after being subjected to sand and dust as encountered in dry arid areas according to requirements of MIL-STD-810E.

Salt Fog

The VR-500 LRUs are resistant to the corrosive effects of salt fog environment according to MIL-STD-810E.

Thermal Design

The cooling of the LRUs is accomplished by conduction through the aluminum enclosure of the units.

Electromagnetic Interference:

VR-500 LRUs as specified with its internal boards, complies to MIL-STD-461E.

- ◆ CE101 Conducted Emissions, Power Leads, 30Hz - 10kHz
- ◆ CE102 Conducted Emissions, Power Leads, 10kHz - 10MHz
- ◆ CS101 Conducted Susceptibility, Power Leads, 30Hz - 50kHz
- ◆ RE102 Radiated Emissions, Electric Field, 100kHz - 10GHz
- ◆ RS101 Radiated Susceptibility, Magnetic Field, 30Hz - 100kHz

Compliance with MIL-STD-704A

The primary Power source of the DataLink is provided from the 115VAC/400Hz/1 aircraft Power source. The input Power characteristics shall be in accordance with Table I of MIL-STD-704A, for Category B equipment.

Minimum: 88VAC 400Hz

Nominal: 115VAC 400 Hz

Maximum: 125VAC 400 Hz

Power Hold-Up Time: 50 mSec

Momentary peak: (0.5 sec) 135 v ac 400Hz

Input Frequency: 365 Hz - 420 Hz

Reliability

MTBF

The DataLink LRUs have an MTBF of 4000 hours.

MTTR

Mean Time To Repair will not exceed 30minutes.